



TOP/SEAL

SEAL IS SOMETHING · QUALITY IS EVERYTHING

T-SEAL STANDARD DESIGN

T-Seal

Seal Materials
NBR
FKM
HNBR
EPDM
Back-up Ring Materials
PTFE
Nylon
PEEK

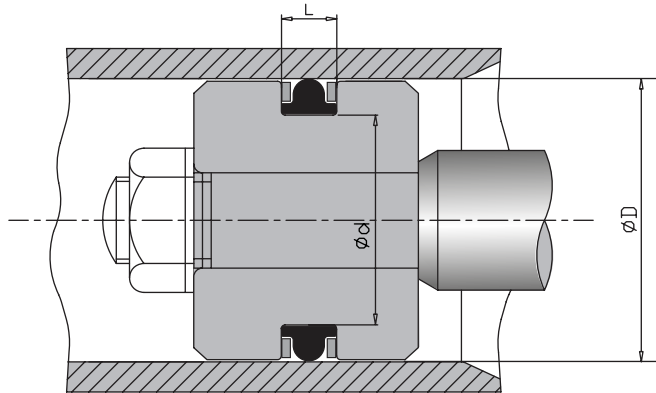

Code	Dimensions				Gland Dimensions(mm)			Gland Dimensions(inch)		
	T-SEAL (AS-568) Dash Number	Nominal (Inch)			Bore Dia. (Cylinder) D	Groove Dia. (Piston) d	No BACK-UP Width L + 0.13 - 0.00	Bore Dia. (Cylinder) D	Groove Dia. (Piston) d	No BACK-UP Width L + 0.005 - 0.000
		ID	OD	CS						
T001-201	201	3/16	7/16	1/8	11.10	4.95	4.75	0.437	0.195	0.187
T001-202	202	1/4	1/2		12.70	6.55		0.500	0.258	
T001-203	203	5/16	9/16		14.27	8.13		0.562	0.320	
T001-204	204	3/8	5/8		15.88	9.73		0.625	0.383	
T001-205	205	7/16	11/16		17.45	11.30		0.687	0.445	
T001-206	206	1/2	3/4		19.05	12.90		0.750	0.508	
T001-207	207	9/16	13/16		20.62	14.48		0.812	0.570	
T001-208	208	5/8	7/8		22.23	16.08		0.875	0.633	
T001-209	209	11/16	15/16		23.80	17.65		0.937	0.695	
T001-210	210	3/4	1		25.40	19.25		1.000	0.758	
T001-211	211	13/16	1 1/16		26.97	20.83		1.062	0.820	
T001-212	212	7/8	1 1/8		28.58	22.43		1.125	0.883	
T001-213	213	15/16	1 3/16		30.15	24.00		1.187	0.945	
T001-214	214	1	1 1/4		31.75	25.60		1.250	1.008	
T001-215	215	1 1/16	1 5/16		33.32	27.18		1.312	1.070	
T001-216	216	1 1/8	1 3/8		34.93	28.78		1.375	1.133	
T001-217	217	1 3/16	1 7/16		36.50	30.35		1.437	1.195	
T001-218	218	1 1/4	1 1/2		38.10	31.95		1.500	1.258	
T001-219	219	1 5/16	1 9/16		39.67	33.53		1.562	1.320	
T001-220	220	1 3/8	1 5/8		41.28	35.13		1.625	1.383	
T001-221	221	1 7/16	1 11/16	42.85	36.70	1.687	1.445			
T001-222	222	1 1/2	1 3/4	44.45	38.30	1.750	1.508			
T001-309	309	7/16	13/16	3/16	20.62	11.23	7.14	0.812	0.442	0.281
T001-310	310	1/2	7/8		22.23	12.83		0.875	0.505	
T001-311	311	9/16	15/16		23.80	14.40		0.937	0.567	
T001-312	312	5/8	1		25.40	16.00		1.000	0.630	
T001-313	313	11/16	1 1/16		26.97	17.58		1.062	0.692	
T001-314	314	3/4	1 1/8		28.55	19.18		1.124	0.755	
T001-315	315	13/16	1 3/16		30.15	20.75		1.187	0.817	
T001-316	316	7/8	1 1/4		31.75	22.35		1.250	0.880	
T001-317	317	15/16	1 5/16		33.32	23.93		1.312	0.942	
T001-318	318	1	1 3/8		34.93	25.53		1.375	1.005	
T001-319	319	1 1/16	1 7/16		36.50	27.10		1.437	1.067	

T-Seal

Code	Dimensions			Gland Dimensions(mm)			Gland Dimensions(Inch)						
	T-SEAL (AS-568) Dash Number	Nominal (Inch)		Bore Dia. (Cylinder)	Groove Dia. (Piston)	No BACK-UP Width	Bore Dia. (Cylinder)	Groove Dia. (Piston)	No BACK-UP Width				
		ID	OD							CS	D	d	L + 0.13 - 0.00
T001-320	320	1 1/8	1 1/2	3/16	38.10	28.70	7.14	1.500	1.130	0.281			
T001-321	321	1 3/16	1 9/16		39.67	30.28		1.562	1.192				
T001-322	322	1 1/4	1 5/8		41.28	31.88		1.625	1.255				
T001-323	323	1 5/16	1 11/16		42.85	33.45		1.687	1.317				
T001-324	324	1 3/8	1 3/4		44.45	35.05		1.750	1.380				
T001-325	325	1 1/2	1 7/8		47.63	38.23		1.875	1.505				
T001-326	326	1 5/8	2		50.80	41.40		2.000	1.630				
T001-327	327	1 3/4	2 1/8		53.98	44.58		2.125	1.755				
T001-328	328	1 7/8	2 1/4		57.15	47.75		2.250	1.880				
T001-329	329	2	2 3/8		60.33	50.93		2.375	2.005				
T001-330	330	2 1/8	2 1/2		63.50	54.10		2.500	2.130				
T001-331	331	2 1/4	2 5/8		66.68	57.28		2.625	2.255				
T001-332	332	2 3/8	2 3/4		69.85	60.45		2.750	2.380				
T001-333	333	2 1/2	2 7/8		73.03	63.63		2.875	2.505				
T001-334	334	2 5/8	3		76.20	66.80		3.000	2.630				
T001-335	335	2 3/4	3 1/8		79.38	69.98		3.125	2.755				
T001-336	336	2 7/8	3 1/4		82.55	73.15		3.250	2.880				
T001-337	337	3	3 3/8		85.73	76.33		3.375	3.005				
T001-338	338	3 1/8	3 1/2		88.90	79.50		3.500	3.130				
T001-339	339	3 1/4	3 5/8		92.08	82.68		3.625	3.255				
T001-340	340	3 3/8	3 3/4		95.25	85.85		3.750	3.380				
T001-341	341	3 1/2	3 7/8		98.43	89.03		3.875	3.505				
T001-342	342	3 5/8	4		101.60	92.20		4.000	3.630				
T001-343	343	3 3/4	4 1/8		104.78	95.38		4.125	3.755				
T001-344	344	3 7/8	4 1/4		107.95	98.55		4.250	3.880				
T001-345	345	4	4 3/8		111.13	101.73		4.375	4.005				
T001-346	346	4 1/8	4 1/2		114.30	104.90		4.500	4.130				
T001-347	347	4 1/4	4 5/8		117.48	108.08		4.625	4.255				
T001-348	348	4 3/8	4 3/4		120.65	111.25		4.750	4.380				
T001-349	349	4 1/2	4 7/8		123.83	114.43		4.875	4.505				
T001-425	425	4 1/2	5		1/4	127.05		115.01	9.53		5.002	4.528	0.375
T001-426	426	4 5/8	5 1/8			130.23		118.19			5.127	4.653	
T001-427	427	4 3/4	5 1/4			133.40		121.36			5.252	4.778	
T001-428	428	4 7/8	5 3/8			136.58		124.54			5.377	4.903	
T001-429	429	5	5 1/2	139.75		127.71	5.502	5.028					
T001-430	430	5 1/8	5 5/8	142.93		130.89	5.627	5.153					
T001-431	431	5 1/4	5 3/4	146.10		134.06	5.752	5.278					
T001-432	432	5 3/8	5 7/8	149.28		137.24	5.877	5.403					
T001-433	433	5 1/2	6	152.45		140.41	6.002	5.528					
T001-434	434	5 5/8	6 1/8	155.63		143.59	6.127	5.653					
T001-435	435	5 3/4	6 1/4	158.80		146.76	6.252	5.778					
T001-436	436	5 7/8	6 3/8	161.98		149.94	6.377	5.903					
T001-437	437	6	6 1/2	165.15		153.11	6.502	6.028					
T001-438	438	6 1/4	6 3/4	171.50		159.46	6.752	6.278					
T001-439	439	6 1/2	7	177.85		165.81	7.002	6.528					
T001-440	440	6 3/4	7 1/4	184.20		172.16	7.252	6.778					

T-Seal

Code	Dimensions			Gland Dimensions(mm)			Gland Dimensions(Inch)			
	T-SEAL (AS-568) Dash Number	Nominal (Inch)		Bore Dia. (Cylinder)	Groove Dia. (Piston)	No BACK-UP Width	Bore Dia. (Cylinder)	Groove Dia. (Piston)	No BACK-UP Width	
		ID	OD							CS
T001-441	441	7	7 1/2	1/4	190.55	178.51	9.53	7.502	7.028	0.375
T001-442	442	7 1/4	7 3/4		196.90	184.86		7.752	7.278	
T001-443	443	7 1/2	8		203.25	191.21		8.002	7.528	
T001-444	444	7 3/4	8 1/4		209.60	197.56		8.252	7.778	
T001-445	445	8	8 1/2		215.95	203.91		8.502	8.028	
T001-446	446	8 1/2	9		228.65	216.61		9.002	8.528	
T001-447	447	9	9		241.35	229.31		9.502	9.028	
T001-448	448	9 1/2	10		254.05	242.01		10.002	9.528	
T001-449	449	10	10 1/2		266.75	254.71		10.502	10.028	
T001-450	450	10 1/2	11		279.45	267.41		11.002	10.528	
T001-451	451	11	11 1/2		292.15	280.11		11.502	11.028	
T001-452	452	11 1/2	12		304.85	292.81		12.002	11.528	
T001-453	453	12	12 1/2		317.55	305.51		12.502	12.028	
T001-454	454	12 1/2	13		330.25	318.21		13.002	12.528	
T001-455	455	13	13 1/2		342.95	330.91		13.502	13.028	
T001-456	456	13 1/2	14		355.65	343.61		14.002	13.528	
T001-457	457	14	14 1/2		368.35	356.31		14.502	14.028	
T001-458	458	14 1/2	15		381.05	369.01		15.002	14.528	
T001-459	459	15	15 1/2		393.75	381.71		15.502	15.028	
T001-460	460	15 1/2	16		406.45	394.41		16.002	15.528	
T001-462	462	16 1/2	17	431.85	419.81	17.002	16.528			

T-Seal

Seal Materials
NBR
FKM
HNBR
EPDM
Back-up Ring Materials
PTFE
Nylon
PEEK

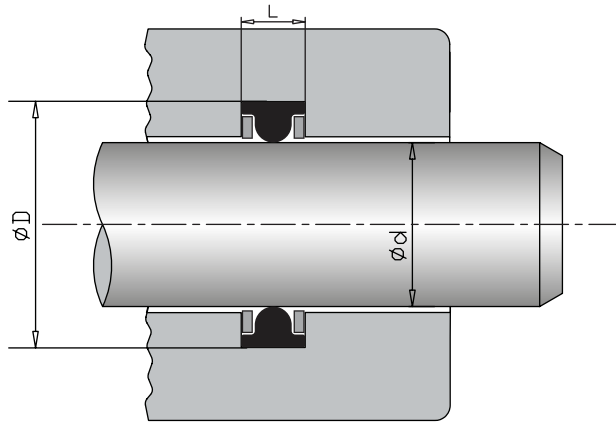

Code	Dimensions				Gland Dimensions (mm)			Gland Dimensions (Inch)		
	T-SEAL (AS-568) Dash Number	Nominal (Inch)		CS	Groove Dia. (Rod Gland) D	Rod Diameter d	No BACK-UP Width L + 0.13 - 0.00	Groove Dia. (Rod Gland) D	Rod Diameter d	No BACK-UP Width L + 0.005 - 0.000
		ID	OD							
T002-201	201	3/16	7/16	1/8	10.85	4.70	4.75	0.427	0.185	0.187
T002-202	202	1/4	1/2		12.45	6.30		0.490	0.248	
T002-203	203	5/16	9/16		14.02	7.87		0.552	0.310	
T002-204	204	3/8	5/8		15.62	9.47		0.615	0.373	
T002-205	205	7/16	11/16		17.20	11.05		0.677	0.435	
T002-206	206	1/2	3/4		18.80	12.65		0.740	0.498	
T002-207	207	9/16	13/16		20.37	14.22		0.802	0.560	
T002-208	208	5/8	7/8		21.97	15.82		0.865	0.623	
T002-209	209	11/16	15/16		23.55	17.40		0.927	0.685	
T002-210	210	3/4	1		25.15	19.00		0.990	0.748	
T002-211	211	13/16	1 1/16		26.72	20.57		1.052	0.810	
T002-212	212	7/8	1 1/8		28.32	22.17		1.115	0.873	
T002-213	213	15/16	1 3/16		29.90	23.75		1.177	0.935	
T002-214	214	1	1 1/4		31.50	25.35		1.240	0.998	
T002-215	215	1 1/16	1 5/16		33.07	26.92		1.302	1.060	
T002-216	216	1 1/8	1 3/8		34.67	28.52		1.365	1.123	
T002-217	217	1 3/16	1 7/16		36.25	30.10		1.427	1.185	
T002-218	218	1 1/4	1 1/2		37.85	31.70		1.490	1.248	
T002-219	219	1 5/16	1 9/16		39.42	33.27		1.552	1.310	
T002-220	220	1 3/8	1 5/8		41.02	34.87		1.615	1.373	
T002-221	221	1 7/16	1 11/16	42.60	36.45	1.677	1.435			
T002-222	222	1 1/2	1 3/4	44.20	38.05	1.740	1.498			
T002-309	309	7/16	13/16	3/16	20.45	11.05	7.14	0.805	0.435	0.281
T002-310	310	1/2	7/8		22.05	12.65		0.868	0.498	
T002-311	311	9/16	15/16		23.62	14.22		0.930	0.560	
T002-312	312	5/8	1		25.22	15.82		0.993	0.623	
T002-313	313	11/16	1 1/16		26.80	17.40		1.055	0.685	
T002-314	314	3/4	1 1/8		28.40	19.00		1.118	0.748	
T002-315	315	13/16	1 3/16		29.97	20.57		1.180	0.810	
T002-316	316	7/8	1 1/4		31.57	22.17		1.243	0.873	
T002-317	317	15/16	1 5/16		33.15	23.75		1.305	0.935	
T002-318	318	1	1 3/8		34.75	25.35		1.368	0.998	

T-Seal

Code	Dimensions				Gland Dimensions (mm)			Gland Dimensions (Inch)		
	T-SEAL (AS-568) Dash Number	Nominal (Inch)		CS	Groove Dia. (Rod Gland) D	Rod Diameter d	No BACK-UP Width L + 0.13 - 0.00	Groove Dia. (Rod Gland) D	Rod Diameter d	No BACK-UP Width L + 0.005 - 0.000
		ID	OD							
T002-319	319	1 1/16	1 7/16	3/16	36.32	26.92	7.14	1.430	1.060	0.281
T002-320	320	1 1/8	1 1/2		37.92	28.52		1.493	1.123	
T002-321	321	1 3/16	1 9/16		39.50	30.10		1.555	1.185	
T002-322	322	1 1/4	1 5/8		41.10	31.70		1.618	1.248	
T002-323	323	1 5/16	1 11/16		42.67	33.27		1.680	1.310	
T002-324	324	1 3/8	1 3/4		44.27	34.87		1.743	1.373	
T002-325	325	1 1/2	1 7/8		47.45	38.05		1.868	1.498	
T002-326	326	1 5/8	2		50.62	41.22		1.993	1.623	
T002-327	327	1 3/4	2 1/8		53.80	44.40		2.118	1.748	
T002-328	328	1 7/8	2 1/4		56.97	47.57		2.243	1.873	
T002-329	329	2	2 3/8		60.15	50.75		2.368	1.998	
T002-330	330	2 1/8	2 1/2		63.32	53.92		2.493	2.123	
T002-331	331	2 1/4	2 5/8		66.50	57.10		2.618	2.248	
T002-332	332	2 3/8	2 3/4		69.67	60.27		2.743	2.373	
T002-333	333	2 1/2	2 7/8		72.85	63.45		2.868	2.498	
T002-334	334	2 5/8	3		76.02	66.62		2.993	2.623	
T002-335	335	2 3/4	3 1/8		79.20	69.80		3.118	2.748	
T002-336	336	2 7/8	3 1/4		82.37	72.97		3.243	2.873	
T002-337	337	3	3 3/8		85.55	76.15		3.368	2.998	
T002-338	338	3 1/8	3 1/2		88.72	79.32		3.493	3.123	
T002-339	339	3 1/4	3 5/8		91.90	82.50		3.618	3.248	
T002-340	340	3 3/8	3 3/4		95.07	85.67		3.743	3.373	
T002-341	341	3 1/2	3 7/8		98.25	88.85		3.868	3.498	
T002-342	342	3 5/8	4		101.42	92.02		3.993	3.623	
T002-343	343	3 3/4	4 1/8		104.60	95.20		4.118	3.748	
T002-344	344	3 7/8	4 1/4		107.77	98.37		4.243	3.873	
T002-345	345	4	4 3/8		110.95	101.55		4.368	3.998	
T002-346	346	4 1/8	4 1/2		114.12	104.72		4.493	4.123	
T002-347	347	4 1/4	4 5/8		117.30	107.90		4.618	4.248	
T002-348	348	4 3/8	4 3/4		120.47	111.07		4.743	4.373	
T002-349	349	4 1/2	4 7/8		123.65	114.25		4.868	4.498	
T002-425	425	4 1/2	5		126.26	114.22		4.971	4.497	
T002-426	426	4 5/8	5 1/8		129.44	117.40		5.096	4.622	
T002-427	427	4 3/4	5 1/4		132.61	120.57		5.221	4.747	
T002-428	428	4 7/8	5 3/8	135.79	123.75	5.346	4.872			
T002-429	429	5	5 1/2	138.96	126.92	5.471	4.997			
T002-430	430	5 1/8	5 5/8	142.14	130.10	5.596	5.122			
T002-431	431	5 1/4	5 3/4	145.31	133.27	5.721	5.247			
T002-432	432	5 3/8	5 7/8	148.49	136.45	5.846	5.372			
T002-433	433	5 1/2	6	151.66	139.62	5.971	5.497			
T002-434	434	5 5/8	6 1/8	154.84	142.80	6.096	5.622			
T002-435	435	5 3/4	6 1/4	158.01	145.97	6.221	5.747			
T002-436	436	5 7/8	6 3/8	161.19	149.15	6.346	5.872			
T002-437	437	6	6 1/2	164.36	152.32	6.471	5.997			
T002-438	438	6 1/4	6 3/4	170.71	158.67	6.721	6.247			
T002-439	439	6 1/2	7	177.06	165.02	6.971	6.497			

T-Seal

Code	Dimensions			Gland Dimensions (mm)			Gland Dimensions (Inch)			
	T-SEAL (AS-568) Dash Number	Nominal (Inch)		Groove Dia. (Rod Gland)	Rod Diameter	No BACK-UP Width	Groove Dia. (Rod Gland)	Rod Diameter	No BACK-UP Width	
		ID	OD							CS
T002-440	440	6 3/4	7 1/4	1/4	183.41	171.37	9.53	7.221	6.747	0.375
T002-441	441	7	7 1/2		189.76	177.72		7.471	6.997	
T002-442	442	7 1/4	7 3/4		196.11	184.07		7.721	7.247	
T002-443	443	7 1/2	8		202.46	190.42		7.971	7.497	
T002-444	444	7 3/4	8 1/4		208.81	196.77		8.221	7.747	
T002-445	445	8	8 1/2		215.16	203.12		8.471	7.997	
T002-446	446	8 1/2	9		227.86	215.82		8.971	8.497	
T002-447	447	9	9		240.56	228.52		9.471	8.997	
T002-448	448	9 1/2	10		253.26	241.22		9.971	9.497	
T002-449	449	10	10 1/2		265.96	253.92		10.471	9.997	
T002-450	450	10 1/2	11		278.66	266.62		10.971	10.497	
T002-451	451	11	11 1/2		291.36	279.32		11.471	10.997	
T002-452	452	11 1/2	12		304.06	292.02		11.971	11.497	
T002-453	453	12	12 1/2		316.76	304.72		12.471	11.997	
T002-454	454	12 1/2	13		329.46	317.42		12.971	12.497	
T002-455	455	13	13 1/2		342.16	330.12		13.471	12.997	
T002-456	456	13 1/2	14		354.86	342.82		13.971	13.497	
T002-457	457	14	14 1/2		367.56	355.52		14.471	13.997	
T002-458	458	14 1/2	15		380.26	368.22		14.971	14.497	
T002-459	459	15	15 1/2		392.96	380.92		15.471	14.997	
T002-460	460	15 1/2	16		405.66	393.62		15.971	15.497	
T002-462	462	16 1/2	17	431.06	419.02	16.971	16.497			